

A solutions focused approach to commercial refrigeration and display equipment.

Inter-Fridge are a leading supplier of high-quality display and storage equipment to Food Outlets, C-Stores, Supermarkets, Restaurants and more. We provide food and beverage solutions to suit a busy commercial environment that allow maximum merchandising opportunities.





Modular Convenience Counter

Fri-Jado believe in enriching the food-to-go and food retail environment through superior quality equipment and innovation.



MCC Modular Convenience Counter range

- Hot  and cold 
- Self serve (open and closed) and full serve
- For packaged and unpackaged food
- Frameless
- Double Glazed
- Uninterrupted view of product
- Various widths

- Temperature controlled – Ambient, refrigerated and heated cases
- The new MCC is very easy to install and is adaptable to any store design.
- **Both the hot and cold models are available in:**
- Solid back and with soft closing doors on operator side
- Drop-in and floor model with base
- Stand-alone and inline.
- All configurations can be combined in hot and/or cold, side by side.



The MCC Range

Unlimited possibilities and combinations with other hot & cold MCC's



High Capacity



Total Visibility



Best Performance



Mix & Match



Green Efficiency

- 1. High Capacity:** The MCC offers up to 30% more total display surface compared to other brands. Even the smallest counter comes with a large display area and increased shelf space.
- 2. Total Visibility:** Up to 75% more visibility. The innovative design provides a clear 360° view of your products. The MCC cold even has transparent, adjustable shelves.
- 3. Best Performance:** Maximum food safety, extended shelf life and less waste
- 4. Mix and Match:** Unlimited possibilities and combinations with other hot & cold MCC's
- 5. Green Efficiency:** Low total cost of ownership & environmentally friendly green technologies. Like the cold counter, it contains **R290 eco-friendly refrigerant** with **low global warming potential (3GWP)** and holds a **3M1** classification.

Line up Possibilities and Combinations



Various widths



Stand alone and inline

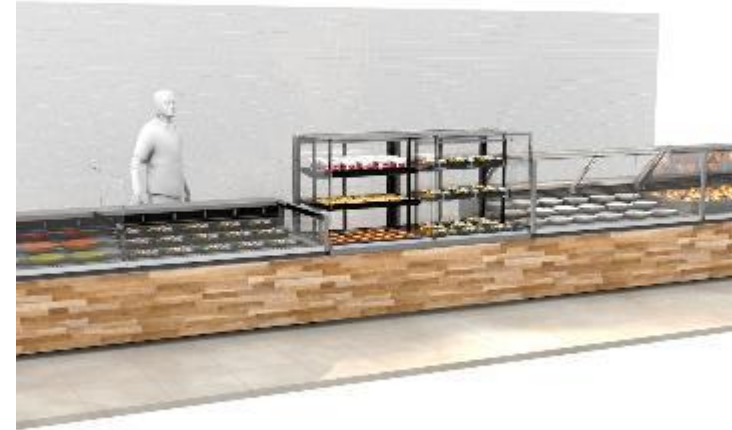

Hot and cold side by side



Including base and drop-in



Self serve and full serve



Ambient and Refrigerated

MCC Counter Range – Ambient / Refrigerated

- All cabinets are supplied with stand
- Colour choice available
- All cabinets have back sliding doors
- Spec sheets available for further information and dimensions.



Back view

High capacity, small footprint

Modular
Convenience
Counter



The Modular Convenience Counters put your food in the spotlight: maximum transparency provides an unobstructed view on your products. All counters have an extra slim design and increased shelf space. High capacity on a small footprint.

The counters are easy to adapt to any store format and store size, available in different widths, hot or cold and even as a drop-in version.

Features MCC Cold self serve

Top features

- High capacity on a small footprint: large display area
- Optimal visibility: clean and clear product display due to transparent sides, top and shelves
- Can be combined with heated Modulal Convenience Counter models
- LED lighting on each shelf
- Best in class performance: OmniCold air flow technology to keep temperatures between -1°C and +5°C (3M1 classification)
- Thermo pane glass - increased insulation
- Product temperature maintained between -1°C and 5°C (3M1)
- Point-of-sales promotion options in price strips
- Maximum flexibility: 90, 120 or 150 cm wide

Standard characteristics

- Inline 3 level refrigerated self serve display cabinet
- Also available as drop-in version
- Slim shelves with adjustable height and angle
- Eco-friendly: green R290 refrigerant
- Ideal for sandwiches, rolls, dairy products, drinks and other meal solutions
- Total display area:
 - MCC 90 cm: 1,18 m²
 - MCC 120 cm: 1,62 m²
 - MCC 150 cm: 2,06 m²



Three presentation levels



OmniCold air flow technology



Optimal visibility

	MCC 90 Cold	MCC 120 Cold	MCC 150 Cold
Width	900 mm	1200 mm	1500 mm
Depth	750 mm	750 mm	750 mm
Height on stand	1420 mm	1420 mm	1420 mm
Height drop-in	1320 mm	1320 mm	1320 mm
Temperature class	3M1	3M1	3M1
Voltage	1N~ 230V	1N~ 230V	1N~ 230V
Frequency	50 Hz	50 Hz	50 Hz
Power	0,48 kW	0,56 kW	0,67 kW
Refrigerant/GWP	R290 / 3	R290 / 3	R290 / 3

MCC 90 Cold

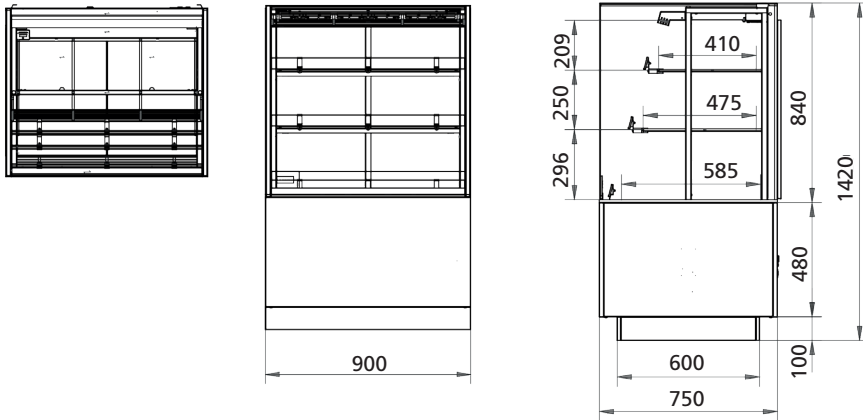

MCC 90 Cold drop-in version

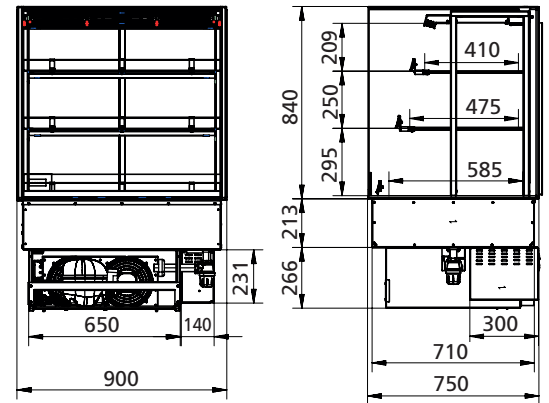

MCC 120 Cold

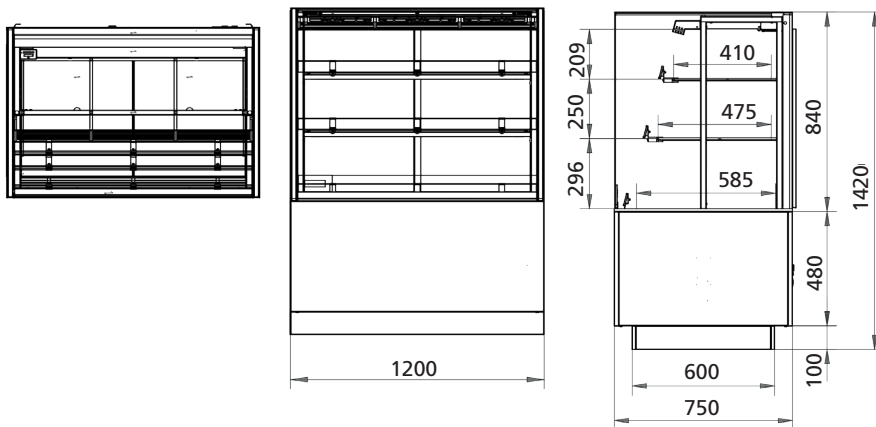

MCC 120 Cold drop-in version

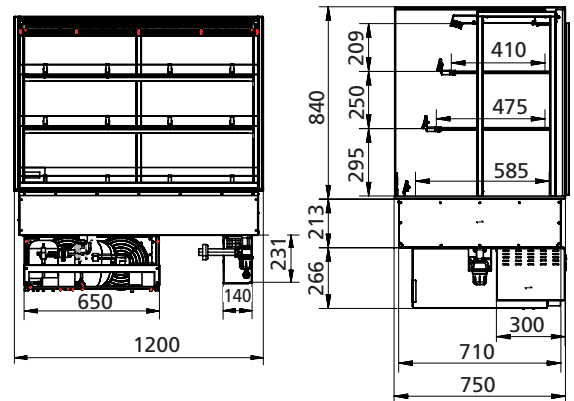

MCC 150 Cold

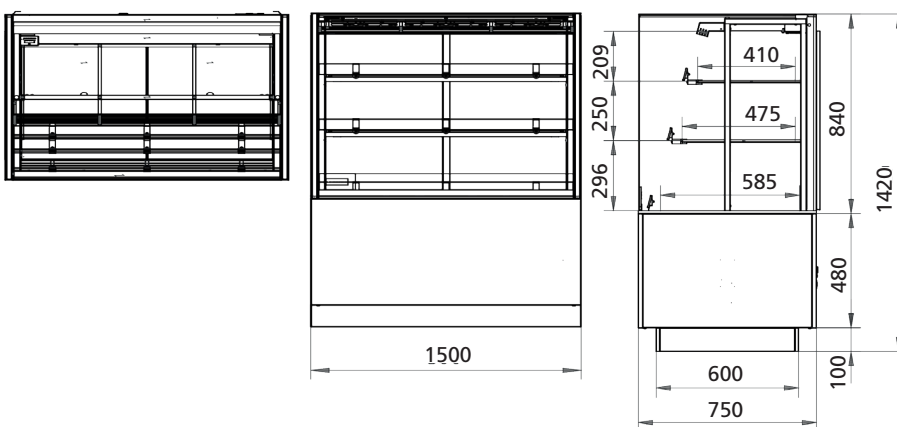

MCC 150 Cold drop-in version

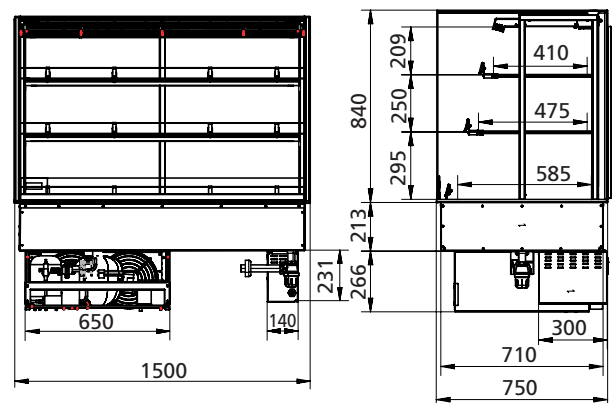

Hot range

- Spec sheets and further information including line drawings, images, and international store references/photos available upon request.



Back view

High capacity, small footprint

Modular
Convenience
Counter



The Modular Convenience Counters put your food in the spotlight: maximum transparency provides an unobstructed view on your products. All counters have an extra slim design and increased shelf space. High capacity on a small footprint.

The counters are easy to adapt to any store format and store size, available in different widths, hot or cold and even as a drop-in version.

Features MCC Hot self serve

Top features

- High capacity on a small footprint: increased shelf space
- Optimal visibility: clear product display due to the transparent sides and top
- Can be combined with refrigerated Modular Convenience Counter models
- LED lighting on each shelf
- Patented Hot Blanket holding technology keeps products warm at $\geq 65^{\circ}\text{C}$
- Hot airflow circulation per shelf
- Thermo pane glass - increased insulation
- Maximum flexibility: 60, 90 or 120 cm wide

Standard characteristics

- Inline 3 level heated self serve display cabinet
- Also available as drop-in version
- Slim shelves with adjustable angle
- Energy efficient: reduced energy consumption
- Optional point-of-sales price strips
- Ideal for hot wraps, pies, pastries, chicken portions and other meal solutions
- Total display area:
 - MCC 60 cm: 0,72 m²
 - MCC 90 cm: 1,15 m²
 - MCC 120 cm: 1,58 m²



Three presentation levels



Patented Hot Blanket holding technology



Optimal visibility

	MCC 60 Hot	MCC 90 Hot	MCC 120 Hot
Width	600 mm	900 mm	1200 mm
Depth	750 mm	750 mm	750 mm
Height on stand	1420 mm	1420 mm	1420 mm
Height drop-in	1053 mm	1053 mm	1053 mm
Voltage	1N~ 230V	1N~ 230V	3N~ 400 / 230V
Frequency	50Hz	50 Hz	50 Hz
Power	1,85 kW	3,02 kW	4,19 kW

MCC 60 Hot

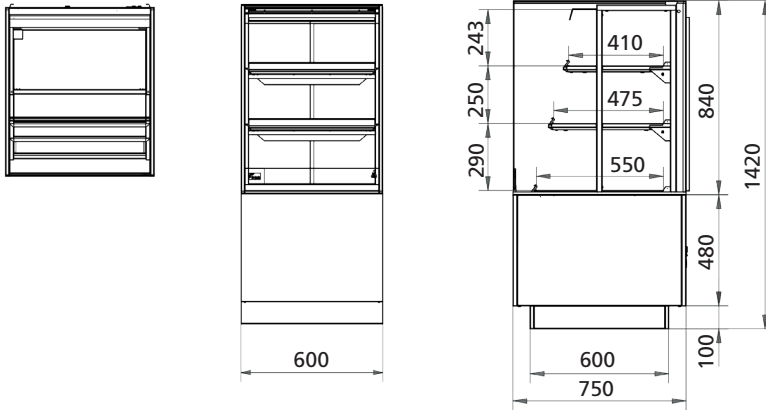

MCC 60 Hot drop-in version

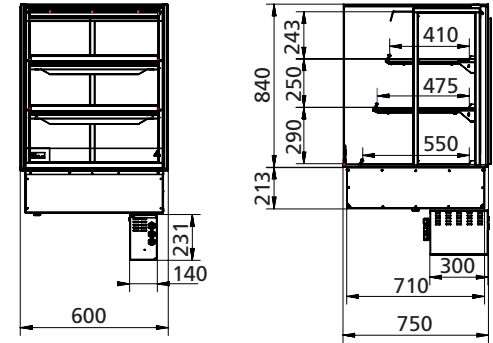

MCC 90 Hot

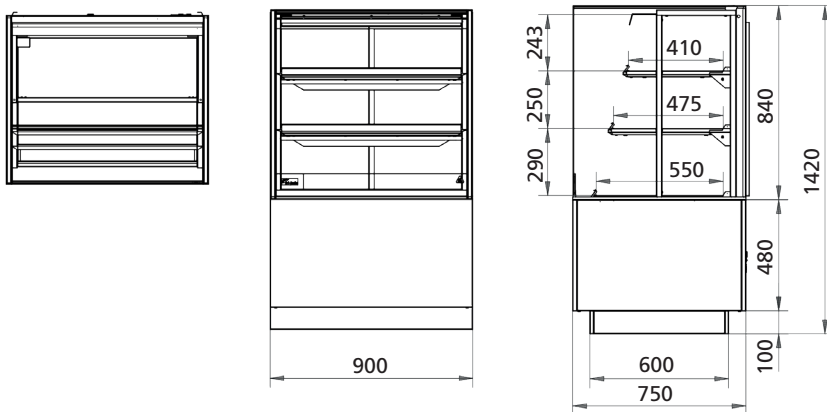

MCC 90 Hot drop-in version

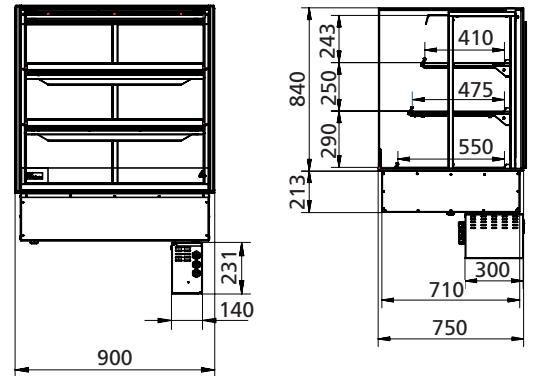

MCC 120 Hot

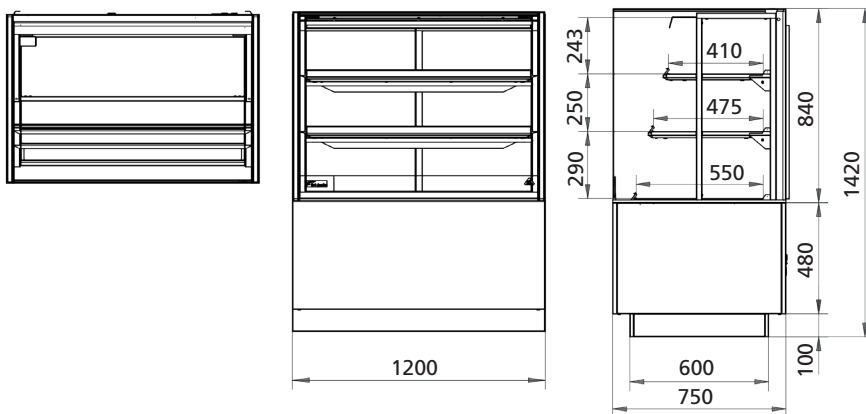

MCC 120 Hot drop-in version

